



**METALLIC BODY RAN 3/4" C
MODEL DIAPHRAGM PUMP
OPERATING AND MAINTENANCE
MANUAL**



INDEX

- 1 Important safety requirements**
- 2 Technical data table**
- 3 Definition of diaphragm pump**
- 4 Handling, moving, opening the package of diaphragm pump**
- 5 Mounting and connection of diaphragm pump**
- 6 Instructions and Manual of diaphragm pump**
- 7 Maintenance**
 - Assembly and dismantling of the parts
 - Periodic maintenance
 - a) Pump cleaning
 - b) Daily maintenance
 - c) Weekly maintenance
 - d) Monthly maintenance
 - e) Troubleshooting
 - Maintenance (servicing and repair)
 - Service points
- 8 Ordering the spares**
- 9 Storage of diaphragm pump**
- 10 Precautions on disposing the diaphragm pump**

Attachment-1 Pump performance charts

Attachment-2 Gisan guarantees

**GİSAN MAKİNE SAN. ve TIC. LTD. STİ.
Birlik Sanayi Sit. 1. Cad No.98-102 Beylikduzu
İSTANBUL TURKEY**

www.ranpump.com

1- IMPORTANT SAFETY REQUIREMENTS

- a- This equipment is for professional use only. Observe all warnings. Read and understand all instruction manuals, warning labels, and tags before you operate the equipment.
- b- **CAUTION: This manual contains important instructions and safety cautions on diaphragm pumps. Read and understand all of it before first use of the pump. Manufacturer is not responsible from the damages and injuries dependant inappropriate use of the pump.**
- c- Diaphragm pump usage is limited with the area defined in this manual.
- d- Never let unqualified / unauthorized people to run diaphragm pump.
- e- Never alter or modify any part of this equipment; doing so could cause it to malfunction. Use only genuine RAN™ Pump parts and accessories.
- f- Supply enough lighting to work.
- g- Do not make changes on the pump which can effect working system of the pump.
- h- Pump maintenance and repair can be done only by the qualified personnel.
- i- Do not surpass the strength of minimum system compound.
- j- Learn hazards or potential dangers of your fluid.
- k- Choose the pump wetted parts material resistant for your media.
- l- Use an approved container for the hazardous media.
- m- Do not pull the pump from the hoses.
- n- Do not let the hoses to twist.
- o- Make sure that hose connections to the pump are tight to avoid air suction.
- p- Do not lift or move the pump while there is pressure in it.
- r- If you are working with flammable or toxic fluids, be sure the system is properly ventilated for your type of installation. You must vent the exhaust to a safe place, away from people, animals, food, and all sources of ignition when pumping flammable or hazardous fluids.
- s- Diaphragm pumps in this technical file are sold only as a pump unit. Control unit is not given with the pump. Operator is responsible to install the suitable control system if needed.



WARNING !
Always wear appropriate clothing and equipment, such as eye protection and breathing apparatus, to protect yourself.



WARNING !
Improper handling of hazardous fluids or inhaling toxic vapors can cause extremely serious injury or death from to splashing in the eyes, ingestion, or bodily contamination. Observe all the following precautions when handling known or potentially hazardous fluids.



WARNING !
Never alter or modify any part of this equipment; doing so could cause it to malfunction. Use only genuine RAN™ parts and accessories.



WARNING !
Never use 1,1,1-trichloroethane, methylene chloride, other halogenated hydrocarbon solvents or fluids containing such solvents in aluminum pumps. Such use could result in a serious chemical reaction, with the possibility of explosion, which could cause death, serious injury, and/or substantial property damage. Consult your fluid suppliers to ensure that the fluids used are compatible with aluminum parts.



WARNING !
If the pump surface temperature is above 80 °C, it is pump owners responsibility to place a warning for the operator not to touch the pump without appropriate protective equipment.

WARNING SYMBOLS ON DIAPHRAGM PUMP

No	Warning	Location on Pump	Instruction
1	About pump working pressure range	On fluid covers	RAN Pump Max: 1 – 7 bar
2	Recommended pump installation scheme	On center section or air valve	Use all the accessories specified in the pump installation scheme

CONFORMITY TO EU DIRECTIVES AND STANDARDS

All the diaphragm pumps produced are comply with the European Community Directive 98/37/EC, Safety of Machinery. These products have used the European Standards listed below to verify conformance.

98/37/EC	Safety of Machinery
EN ISO 12100-1	Safety of machinery - Basic concepts, general principles for design - Part 1: Basic terminology, methodology (ISO 12100-1:2003)
EN ISO 12100-2	Safety of machinery - Basic concepts, general principles for design - Part 2: Technical principles
EN 809	Pumps and pump units for liquids - Common safety requirements
EN 983	Safety of machinery - Safety requirements for fluid power systems and their components - Pneumatics
EN 1050	Safety of machinery - Principles for risk assessment

2- DIAPHRAGM PUMP TECHNICAL DATA

3/4" ALUMINUM PUMP

	Unit	
Pump Type	Inch	3/4" Aluminum
Max. fluid working pressure	Bar	8 (0.8 Mpa, 120 Psi)
Air pressure feeding range	Bar	1.0 to 8.0 bar (0.10 - 0.8 Mpa, 120 Psi)
Max. Air consumption	m ³ /min	0.8
Fluid per cycle	lt/cycle	0.24
Max. Head (for water viscosity)	m	70
Max. Suction depth	m	5
Max. Particle allowance	mm	2.4
Noise power level (at 6 bar)	dBA	90
Max. CAPACITY	lt/min	74
Max. Cycle per minute	Cycle/min	308
Max. Fluid temperature	°C	80 °C
Air inlet	Inch	1/4
Air outlet	Inch	1/2
Fluid inlet	Inch	3/4
Fluid outlet	Inch	3/4
Pump housing material		Aluminum
Weight	kg	9 kg

3- DIAPHRAGM PUMP DEFINITION

Diaphragm pump works with the compressed air coming from compressor. Pump working principle is showed in the below illustration.

There are two valves distributing air in the pump. Outer valve is distributing the air to the diaphragms. Inner air valve is rotating the outer valve.

If a pump works in biggest capacity continuously it will have diaphragm and valve problems soon. So pump must be chosen with bigger capacity and must not use in max. pressures.

Air operated diaphragm pumps are suitable in transferring the fluids up to 50,000 cP viscosity.

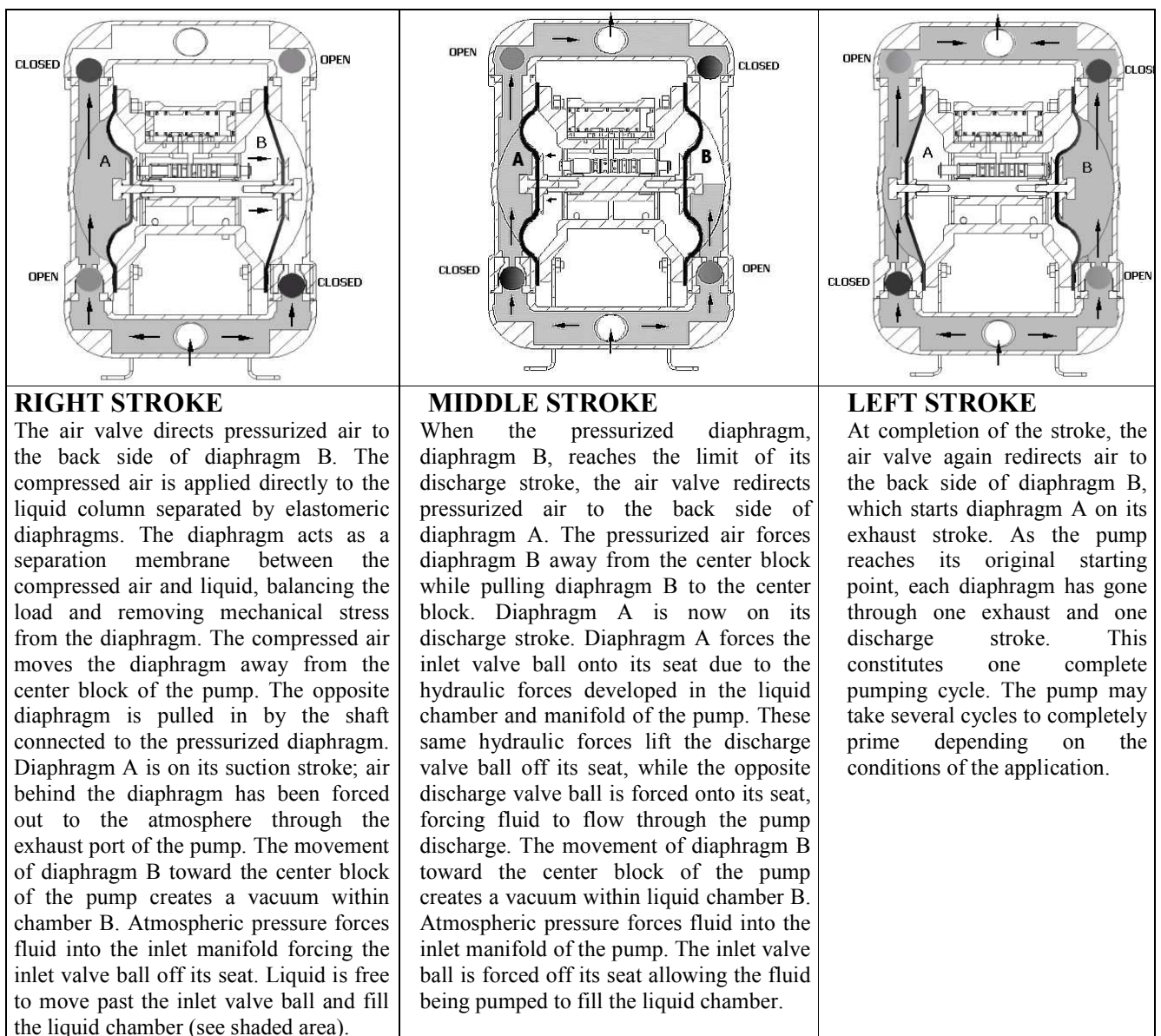

Figure 1- Diaphragm pump working system.

DIAPHRAGM PUMP
OPERATING AND MAINTENANCE MANUAL

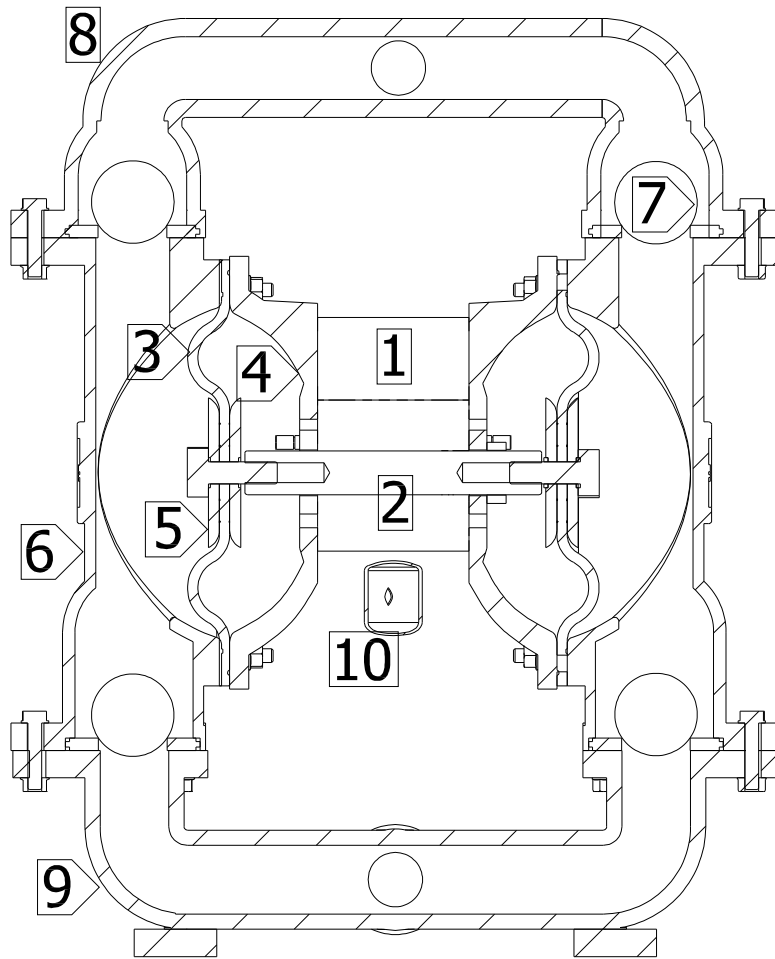

Figure 1 - Diaphragm pump main parts.

No	Description
1	Air valve
2	Center section
3	Diaphragm
4	Air chamber
5	Diaphragm outer flange

No	Description
6	Housing
7	Check valve ball
8	Outlet manifold
9	Inlet manifold
10	Muffler

Diaphragm pump dimensions

Figure 2 – Diaphragm pump main dimensions

4- HANDLING, MOVING, OPENING THE PACKAGE OF DIAPHRAGM PUMP

Handle the pump from manifolds to move.

We put the pumps into carton boxes.

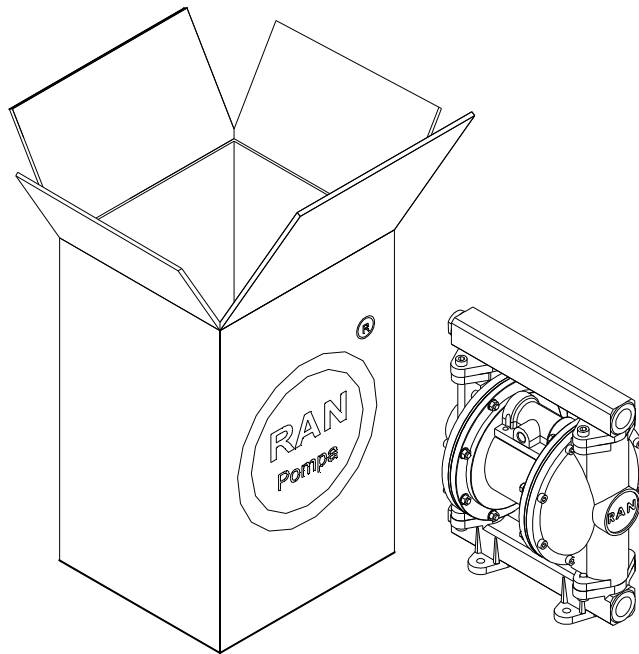

Figure 4 – Pump package.

Pump package must be thick and produced from the kraft carton. It must be fully covered.

Install the pump to desired place in vertical position.

a) **Pump mounting**

Observe the recommendations below when choosing the pump mounting place.

- Must be close to container of the transferred fluid.
- Easy access when operating or maintaining.
- Pump weight to the ground.
- Vibration emission to the ground and other equipments.

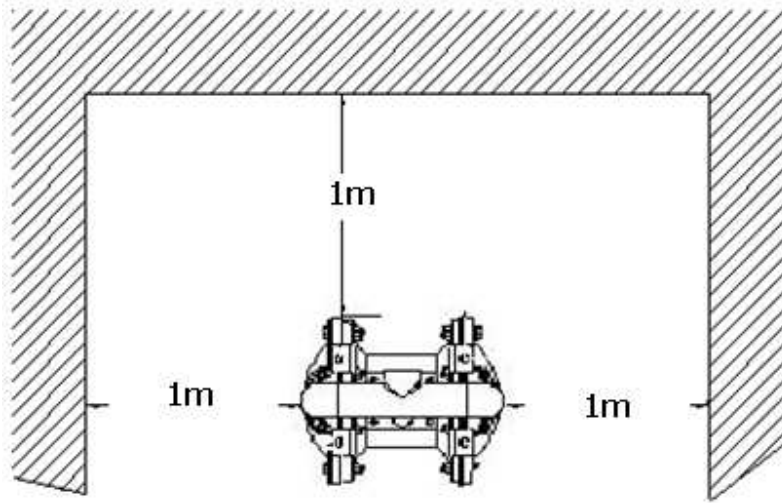

Figure 5 – Minimum space requirement around the diaphragm pump.

5- MOUNTING AND CONNECTION OF DIAPHRAGM PUMP

A typical connection scheme of diaphragm pump is shown at Figure 8. Refer to your RAN™ Pump distributor for detailed information.

Always use genuine RAN™ Pump parts and accessories.

Use a compatible liquid thread sealant on all male threads.



CAUTION !
Do not overtighten the fittings to the pump. Otherwise you can damage the pump.

Tightening the bolts before first use

After you unpack the pump, and before you use it for the first time, check and tighten external fasteners. Tighten the fluid cover screws first, then the manifold screws. This keeps the manifolds from interfering with tightening the fluid covers.

Recommended frequency for tightening fasteners varies with pump usage, a general guideline is to retighten fasteners every two months.

Torque Table

Pump Type	Part	Bolt	Torque N.m
RAN 3/4" M	Air valve	M6	6.8 - 7.6
	Housing	M6	7 - 8
	Manifold	M8	9 - 10
	Diaphragm bolt	M8	17 - 20
	Air Chamber	M8	18 - 20



CAUTION !

To reduce the risk of static sparking, ground the pump and all other equipment used or located in the pumping area.

Ground the pump as it is shown below.

Pump: Grounding wire diameter must be at least 1.5 mm². Connect one end of the wire to a true earth.

Compressor: Follow the manufacturers grounding instructions.

Air and fluid hoses: Use groundable hoses with maximum length of 100 metres.

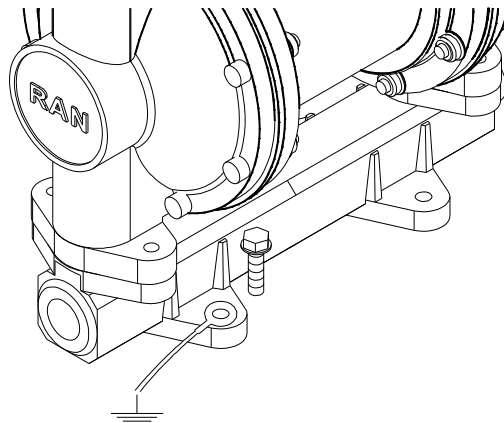

Figure 7- Pump grounding

The pump exhaust air may contain contaminants. Ventilate to a remote area if the contaminants could affect your process.

Fix the pump to the ground from its legs.

COMPRESSED AIR CONNECTION

A bleed-type master air valve is required in your system to relieve air trapped between this valve and the pump. Trapped air can cause the pump to cycle unexpectedly, which could result in serious injury, including splashing in the eyes or on the skin, injury from moving parts, or contamination from hazardous fluids. See Fig. 8.

1- Compressed air line accessories: Refer to the Figure 8 for the connection scheme. Fix these accessories to the wall or to a bracket.

- Install a filter - regulator to the air line. Use a 5 μ (micron) air filter.

- Install an air discharge valve below the pump inlet air line. It will be used after you cut off the main air valve to discharge remaining air in the pump.

2- Use a flexible air hose to the pump air inlet at minimum 3/8 inch (9.5 mm) inner diameter.

FLUID LINE

Fluid suction line

1. Use a flexible, uncollapsible fluid hose with 3/4 inch (19 mm) inner diameter.
2. If the inlet fluid pressure is more than 25% of the outlet working pressure, ball check valves will not close fast enough, result will be inefficient pump operation.
3. At inlet fluid pressures greater than 15 psi (0.1MPa, 1 bar), diaphragm life will be shortened.

Fluid discharge line

1. The pump fluid outlet is 3/4" npt (f). Screw the fluid fitting into the pump outlet securely.
2. Install a fluid drain valve at the pump outlet.
3. Install a fluid shut off valve at the fluid outlet.

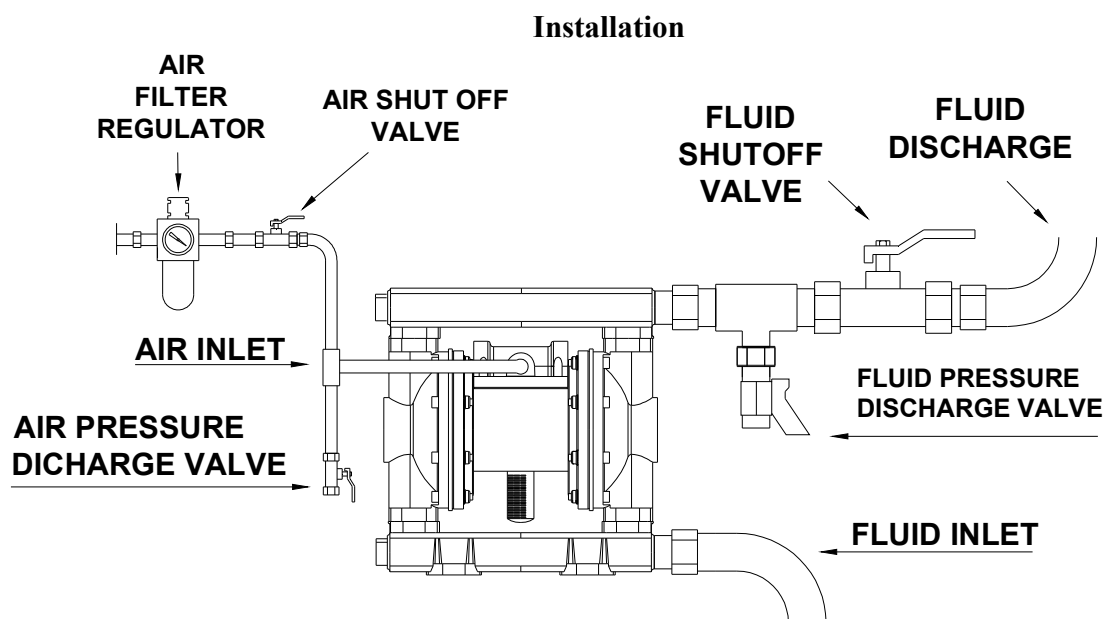

Figure 8- Typical installation

Ventilating Exhaust Air

When transferring hazardous fluids, follow the steps below:

1. Remove the muffler from the exhaust port.
2. Install an air exhaust hose with the minimum diameter.
3. Place a suitable container at the end of exhaust hose to catch the fluid in case diaphragm ruptures.

DIAPHRAGM PUMP
OPERATING AND MAINTENANCE MANUAL

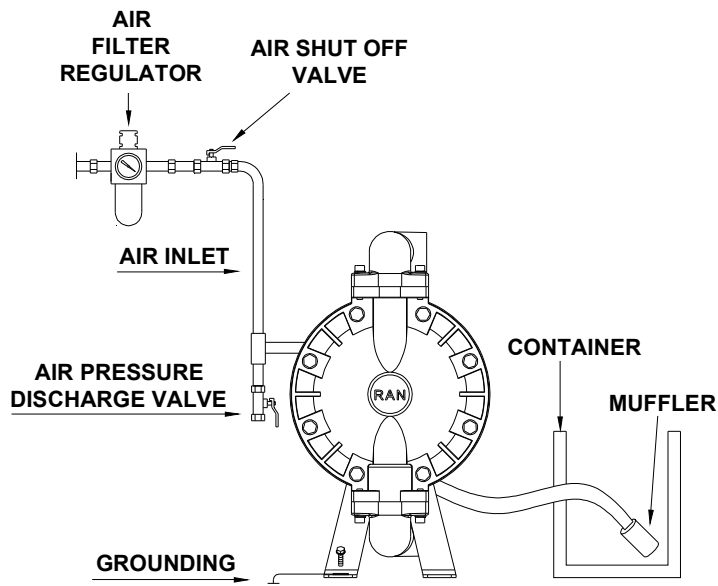

Figure 9- Ventilating exhaust air



WARNING !

When you are transferring hazardous fluids or the pump temperature is over 80°C, operator has to make precautions to drain the fluid.



WARNING ! FIRE AND EXPLOSION HAZARD

If you are working with flammable or toxic fluids, be sure the system is properly ventilated for your type of installation. You must vent the exhaust to a safe place, away from people, animals, food, and all sources of ignition when pumping flammable or hazardous fluids.



WARNING !

Diaphragm pumps are sold as pump unit only. Installing a control device (if needed) is responsibility of the operator.

If the power supply of the pump (compressor) is stopped, the air inlet to the pump must be cut off immediately. Otherwise when compressor restarts, pump may start unexpectedly.

Manual operation: If the power supply of the pump (compressor) is stopped, operator must cut off the air feed to the pump manually.

Automatic operation: If the power supply of the pump (compressor) is stopped, control unit must cut off the air feed to the pump automatically.

6- PUMP OPERATION INSTRUCTIONS

IMPORTANT NOTE

The pump has a variable temperature resistance to the transferred fluid.

Flush the pump before use.

Pump is tested with water. Flush the pump before use if your fluid is effected from water.

Starting and adjusting the pump

- 1- Check pump grounding before use.
- 2- Check fittings to be sure they are tight. Use a compatible liquid thread sealant on male threads. Tighten fluid inlet and outlet fittings securely.
- 3- Place the suction hose inside of the fluid.
- 4- Place discharge hose to a suitable container.
- 5- Turn off the fluid drainage valve.
- 6- Back out the air regulator knob, and open all bleed-type master air valves.
- 7- Set air regulator to 2 bar pressure until the pump primes.
- 8- Pump is tested with water. If you need a clean pump in your process, flush the pump with suitable fluid.



WARNING !

Do not run the pump before you make sure all the adjustments are OK.

Stopping the pump

Cut off the air when the pump is not working.

PRESSURE RELIEF PROCEDURE



WARNING !

PRESSURIZED EQUIPMENT HAZARD

The equipment stays pressurized until pressure is manually relieved. To reduce the risk of serious injury from pressurized fluid, accidental spray from the gun or splashing fluid, follow this procedure whenever you

- Are instructed to relieve pressure
- Stop pumping
- Check, clean or service any system equipment
- Install or clean fluid nozzles

1. Shut off the air to the pump.
2. Open the dispensing valve, if installed.
3. Open the fluid drain valve to relieve fluid pressure, having a container ready to catch the drainage.

7- SERVICE AND MAINTENANCE



WARNING: TOXIC FLUID HAZARD

To reduce the risk of serious injury, splashing in the eyes or on the skin, and toxic fluid spills, never move or lift a pump under pressure. If dropped, the fluid section may rupture. Always follow the Pressure Relief Procedure Warning above before lifting the pump.

ASSEMBLE AND DISMOUNT OF THE PARTS

A- Ball check valve repair

Tools required

- . Torque wrench
- . 7 mm allen key

Dismount

NOTE: To ensure proper seating, you should change the seats with the ball check valves.

1. Relieve the pressure in pump. Remove the hoses.
2. Dismount the pump from the ground.
3. Remove the manifolds using 7 mm allen key.
4. Remove the manifold orings, ball cages, valve balls and ball seats from the pump.
5. Turn the pump over. Remove inlet manifolds.

Mounting

1. Clean all the parts and inspect for wear.
2. You can assemble the pump following the reverse order.

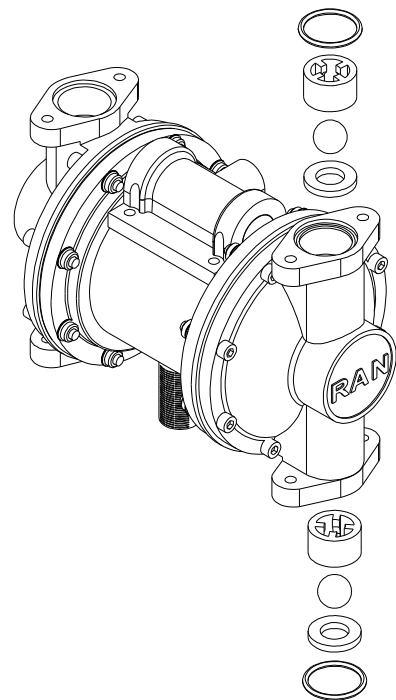

Figure 10- Aluminum pump check valve repair.

B- Changing diaphragm

Tools Required

- . 5 mm allen key
- . 7 mm allen key
- . 10 mm socket wrench
- . 19 mm socket wrench
- . Lithium-base grease (non-freezing silicone grease)

1. Relieve the pressure.
2. Remove the manifolds and disassemble the ball check valves as explained on page 15.
3. Using a 5 mm allen key and 10 mm socket wrench, remove the bolts holding the fluid covers the air covers. Pull the fluid covers off the pump. See Fig. 11.
4. Loosen but do not remove the diaphragm shaft bolts, using a 19 mm socket wrench on both bolts.
5. Remove o-ring, Teflon® diaphragm (if there is) and rubber diaphragm.
6. Pull the other diaphragm assembly and the diaphragm shaft out of the center housing. Hold the shaft with a 19 mm open-end wrench, and remove the bolt from the shaft. Disassemble the remaining diaphragm assembly.
7. Inspect the diaphragm shaft for wear or scratches. If it is damaged, inspect the bearings in place.
8. Remove the tap which holds the pilot shaft and diaphragm shaft.
9. Clean all parts and inspect for wear or damage. Replace parts as needed. Tighten the fluid cover screws.

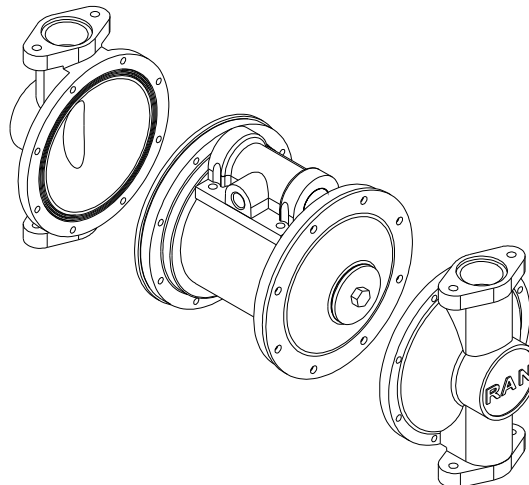

Figure 11- Diaphragm change

C- Air valve repair

Tools Required

- . 5 mm allen key
- . 10 mm socket wrench
- . Z-ring pick
- . Lithium-base grease (non-freezing silicone grease)

NOTE: Hold the air valve vertical position if the core is sliding with its own weight in the valve body, valve z-rings has to be changed.

1. Relieve the pressure.
2. With a 5 mm allen key, remove the four screws, air valve body, and gasket. See Fig. 12.
3. You will see two taps at the sides of the valve. Push a tap with your finger until the valve core comes out.
4. Change the z-rings on the valve core.
5. Make sure you do not damage the z-rings when inserting valve core into the valve body. You can use your finger nail at this operation. Before inserting the core to valve body, grease it slightly with a suitable oil.
6. Reassemble the parts in the reverse order. Make sure that both taps are in a vertical position and parallel to the valve body sides.

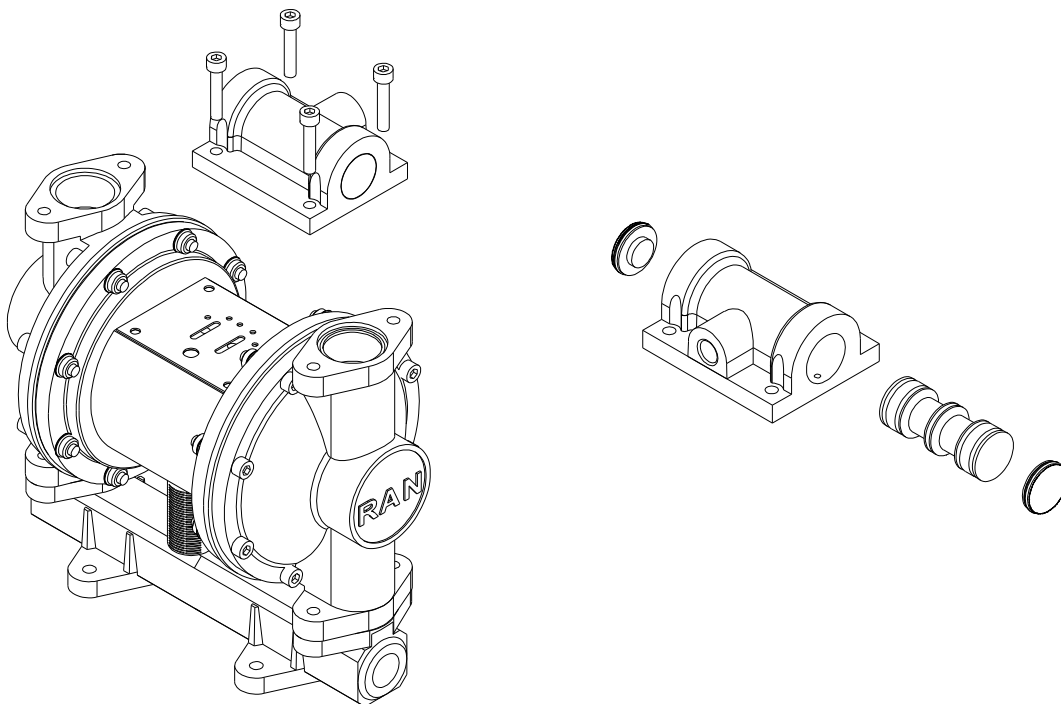

Figure 12- Air valve repair.

PERIODIC MAINTENANCE

Cleaning and storage of the pump

Do not let your fluid dry in the pump or in the hoses. Clean the pump by pumping the suitable solvent of your fluid until the pump is cleaned. Make sure the fluids you are using to be compatible with your diaphragm material. If you will not going to use the pump for a long time, clean the pump and relieve the pressure in the pump.

Tightening the screw connections

Inspect damage on the hoses before every use. Check all the screw connections. Check the screw connections in every two months. First tighten the fluid cover screws than the manifold screws.

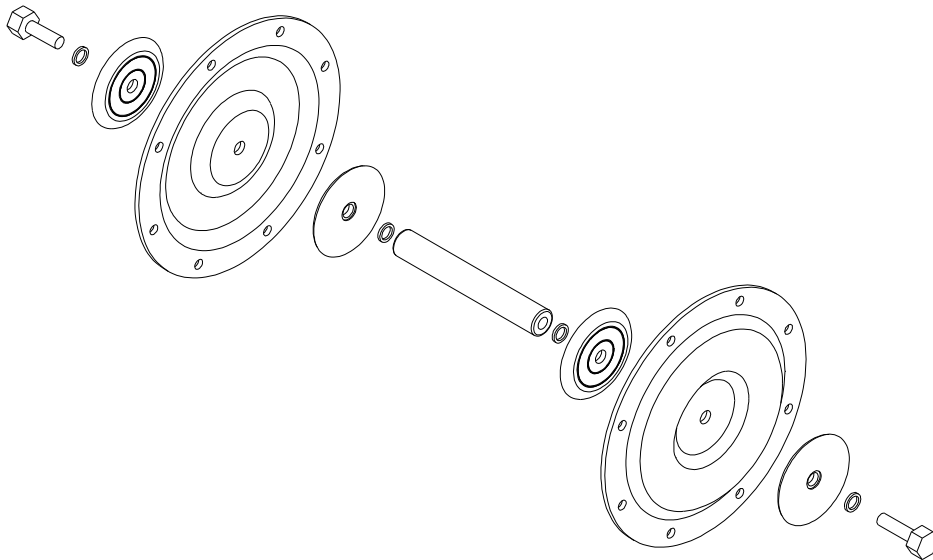

Figure 13 – Diaphragm assembly

A code is written on the fluid side of the diaphragm. Grease the shaft a little with silicon based grease.

In some pumps there is a Teflon® diaphragm on the fluid side of the nubber diaphragm to make them resistant to the fluid transferred.

A- DAILY CARE

- 1- Air line accessories:
 - Air filter: Check if there is water or moisture in the filter,
 - Pressure regulator: Check the air pressure set value.
- 2- Clean the pump by pumping the suitable solvent of your fluid until the pump is cleaned.

B- WEEKLY MAINTENANCE

- 1- Clean the check valve balls and ball seats.

C- MONTHLY MAINTENANCE

- 1- Check the valve balls diameter. Check the inner diameter of the ball seats. Ball diameter must be bigger (at least 1.5 mm) than the inner diameter of the seat. Both of them must have a smooth surface. If there is capacity decrease change the balls and seats both.
- 2- Check the pilot valve and the o-rings.
- 3- Check diaphragms.
- 4- Check the wetted parts of pump.
- 5- After 500 hours of operation or once a month stop the pump. Relieve the pressure in it. Remove the air hose. Put 2 drops of suitable oil to the pump air valve inlet and insert the air hose again.

SERVICE POINTS

If you need technical assistance call **+90 212 875 03 17** or send fax message to **+90 212 875 03 18**.

E-mail / Web : info@ranpump.com / www.ranpump.com

8-SPARE PARTS ORDER

No spare parts given with the diaphragm pump.

9- STORAGE OF THE DIAPHRAGM PUMP

If you are not going to use the pump for a long time, clean it before storage.

In freezing cold weather clean the pump after you done with the pump.

10- DISPOSAL OF THE DIAPHRAGM PUMP

Do the precautions before disposing the pump.

- Discharge the pump completely.
- Disconnect all the hoses.



IMPORTANT NOTE !
First of all refer to relevant laws in your country.

DIAPHRAGM PUMP
OPERATING AND MAINTENANCE MANUAL

Troubleshooting

NOTE: Check all possible problems and causes before you disassemble the pump.

PROBLEM	CAUSE	SOLUTION
Pump cycles at stall or fails to hold pressure at stall.	Worn check valve balls, seats or o-rings.	Replace. See page 15.
Pump will not cycle, or cycles once and stops.	Air valve is stuck or dirty.	Disassemble and clean air valve. See page 17. Use filtered air.
	Check valve ball severely worn and wedged in seat or manifold.	Replace ball and seat. See page 15.
	Check valve ball is wedged into seat, due to overpressurization.	Install a pressure relief valve (see page 12).
	Dispensing valve is clogged.	Relieve pressure and clear valve.
Pump operates erratically.	Suction line is clogged.	Inspect; clear.
	Sticky or leaking check valve balls.	Clean or replace. See page 15.
	Diaphragm is ruptured.	Replace. See page 16.
	Pump is sucking air.	Check inlet hose and inlet manifold o-rings.
	Restricted exhaust.	Remove restriction.
Air bubbles in fluid.	Suction line is loose.	Tighten.
	Diaphragm is ruptured.	Replace. See page 16.
	Loose inlet manifold, damaged seal between manifold and seat, or damaged o-rings.	Tighten manifold bolts, or replace seats or o-rings. See page 11.
	Loose diaphragm shaft bolt.	Replace. See page 16.
	Damaged o-ring.	Replace. See page 16.
Fluid in exhaust air.	Diaphragm is ruptured.	Replace. See page 16.
	Loose diaphragm shaft bolt.	Tighten or replace. See page 16.
	Damaged o-ring.	Replace. See page 16.
Pump leaks air externally.	Air valve is stuck or dirty.	Disassemble and clean air valve. See page 17. Use filtered air.
	Air valve z-rings are damaged.	Disassemble and clean air valve.
	Pilot valve o-rings are damaged.	Disassemble and replace o-rings.
	Air inlet pressure and flow are not enough.	Rise the pressure and flow. See Performance Charts at Page 22.
Pump leaks fluid externally from ball check valves.	Loose manifolds, damaged o-ring between manifold and seat.	Replace o-rings, tighten manifold bolts.
Diaphragm moves to inside of the pump, and fluid leaks from the openings.	Fluid outlet is clogged or outlet valve is closed when the pump is under pressure.	Clean the outlet line or open the fluid outlet valve.
	Max. air pressure is exceeded.	Lower the air pressure.
	The fluid temperature is above the working limits. Adjust the air pressure according to the fluid temperature.	Lower the air pressure.

**DIAPHRAGM PUMP
OPERATING AND MAINTENANCE MANUAL**

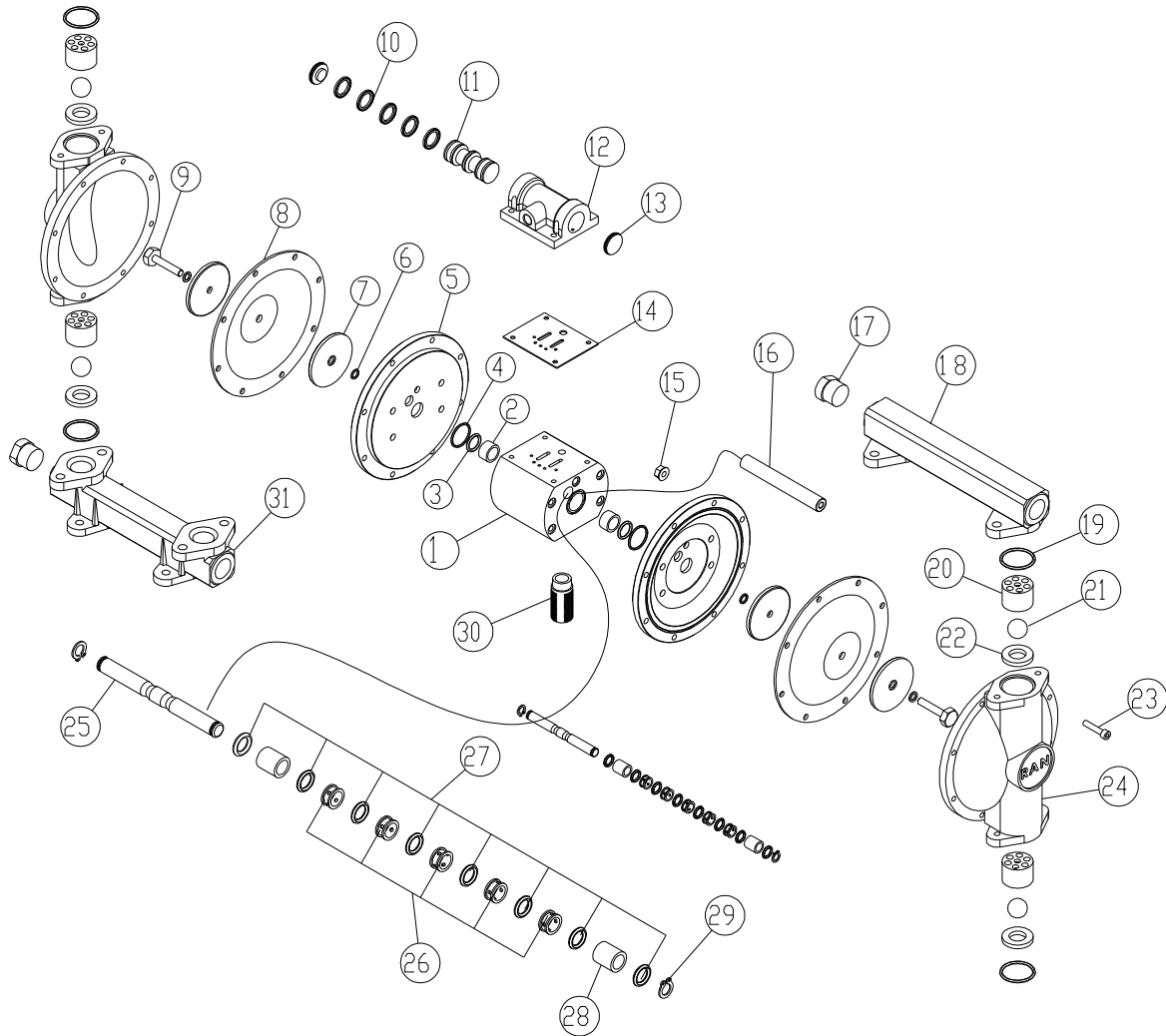

NO	PART	QTY
1	Center Section	1
2	Bushing, Shaft	2
3	O-ring, Shaft	2
4	O-ring, Center Section	2
5	Air Chamber	2
6	O-ring, Flange	4
7	Diaphragm Flange	4
8	Diaphragm	2
9	Diaphragm Bolt	2
10	Valve Zring	5

NO	PART	QTY
11	Valve Core	1
12	Valve Body	1
13	Valve Tap	2
14	Valve Gasket	1
15	M8 Hex Nut	16
16	Shaft	1
17	Blind Tap	2
18	Discharge Manifold	1
19	Manifold O-ring	4
20	Ball Cage	4

NO	PART	QTY
21	Valve ball	4
22	Valve seat	4
23	M8 bolt	16
24	Inlet Manifold	1
25	Pilot shaft	1
26	Bushing Pilot Shaft	8
27	Cage for Pilot Shaft	5
28	O-ring, Pilot Shaft	2
29	Leg	2
30	Muffler	1

Figure 14- Aluminum 3/4" pump parts list.

3/4" DIAPHRAGM PUMP PERFORMANCE CHARTS

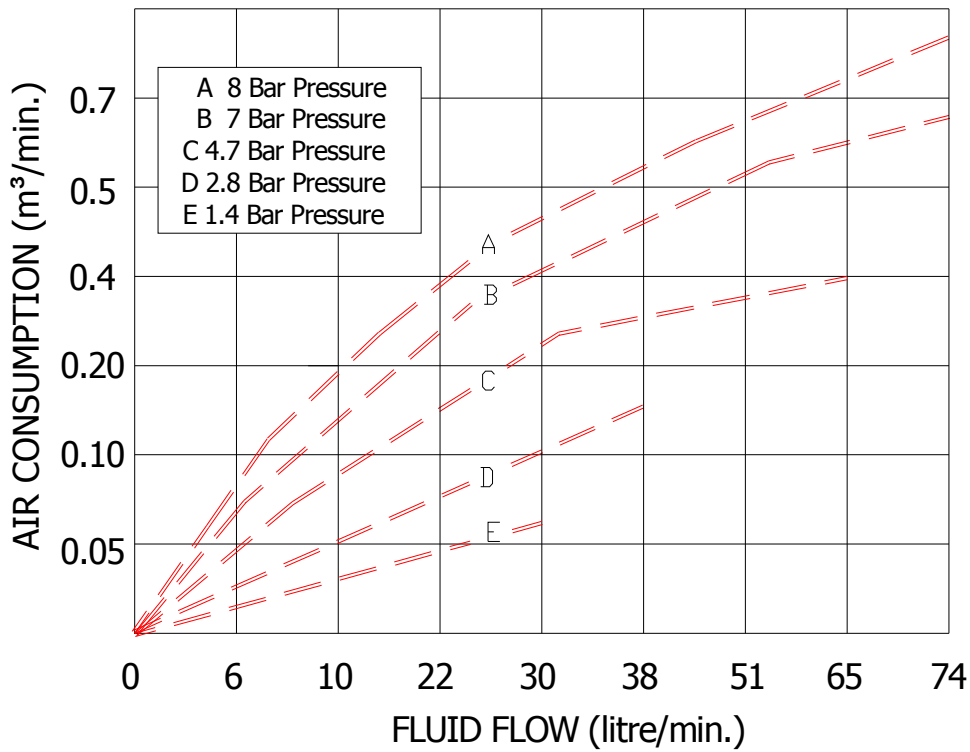
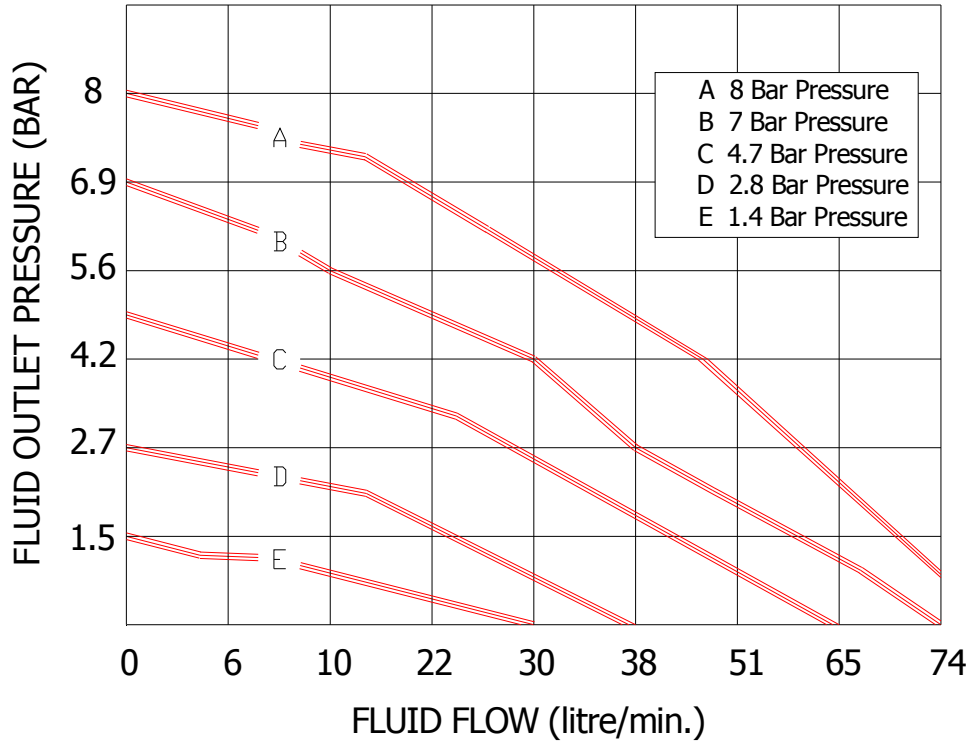

*Reduce the flow by 20% at the charts above, if there is Teflon diaphragms in your pump.

ATTACHMENT-2

GISAN WARRANTIES

Gisan Standard RAN Pump Warranty

Gisan warrants all equipment manufactured by Gisan and bearing its name to be free from defects in material and workmanship on the date of sale to the original purchaser for use. With the exception of any special, extended, or limited warranty published by Gisan, Gisan will, for a period of two years from the date of sale, repair or replace any part of the equipment determined by Gisan to be defective. This warranty applies only when the equipment is installed, operated and maintained in accordance with Gisan's written recommendations.

This warranty does not cover, and Gisan shall not be liable for general wear and tear, or any malfunction, damage or wear caused by faulty installation, misapplication, abrasion, corrosion, inadequate or improper maintenance, negligence, accident, tampering, or substitution of non-Gisan component parts. Nor shall Gisan be liable for malfunction, damage or wear caused by the incompatibility of Gisan equipment with structures, accessories, equipment or materials not supplied by Gisan, or the improper design, manufacture, installation, operation or maintenance of structures, accessories, equipment or materials not supplied by Gisan.

This warranty is conditioned upon the prepaid return of the equipment claimed to be defective to an authorized Gisan distributor for verification of the claimed defect. If the claimed defect is verified, Gisan will repair or replace free of charge any defective parts. The equipment will be returned to the original purchaser transportation prepaid. If inspection of the equipment does not disclose any defect in material or workmanship, repairs will be made at a reasonable charge, which charges may include the costs of parts, labor, and transportation.

Gisan's sole obligation and buyer's sole remedy for any breach of warranty shall be as set forth above. The buyer agrees that no other remedy (including, but not limited to, incidental or consequential damages for lost profits, lost sales, injury to person or property, or any other incidental or consequential loss) shall be available. Any action for breach of warranty must be brought within two years of the date of sale.

Gisan makes no warranty, and disclaims all implied warranties of merchantability and fitness for a particular purpose in connection with accessories, equipment, materials or components sold but not manufactured by Gisan. These items sold, but not manufactured by Gisan (such as hose, etc.), are subject to the warranty, if any, of their manufacturer. Gisan will provide purchaser with reasonable assistance in making any claim for breach of these warranties.

Extended Product Warranty

Gisan warrants all RAN Pump air valve center sections to be free from defects in material and workmanship for a period of two years from date installed in service by the original purchaser. Normal wear of items such as packings are not considered to be defects in material and workmanship.

Five years Gisan will provide spare parts and labor.

Five to ten years Gisan will replace defective parts only.

All written and visual data contained in this document reflects the latest product information available at the time of publication. Gisan reserves the right to make changes at any time without notice.

Gisan Information

If you need further information please contact Gisan distributor in your country or call this number to identify the distributor closest to you.

Tel: +90 212 875 03 17

Fax: +90 212 875 03 18

Gisan Adress: Birlik Sanayi Sitesi 1. Cadde No: 98-102 Beylikduzu istanbul TURKEY

www.ranpump.com

Revision 0